

型號 / type

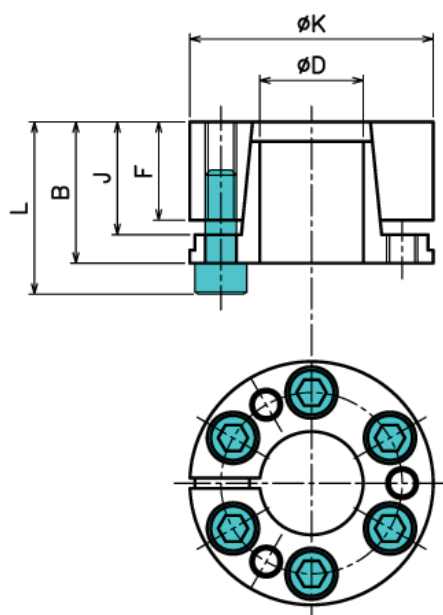

## 免鍵式軸環-自動校心型

單位 /Unit : mm



規格 NO	D	K	F	J	B	L	M	常用 扭力 (N.m)	軸向 荷重 (kN)	輪側 面壓 (N/mm <sup>2</sup> )	重量 (kg)
D-20	20	47	26	31	42	48	M6	550	55	100	0.37
D-22	22	47	26	31	42	48	M6	600	55	100	0.37
D-24	24	50	26	31	42	48	M6	660	55	100	0.4
D-25	25	50	26	31	42	48	M6	680	55	100	0.4
D-28	28	55	26	31	42	48	M6	720	55	100	0.44
D-30	30	55	26	31	42	48	M6	820	55	100	0.53
D-32	32	60	26	31	42	48	M6	1400	80	130	0.52
D-35	35	60	26	31	42	48	M6	1400	80	130	0.5
D-38	38	65	26	31	42	48	M6	1600	80	130	0.6
D-40	40	65	26	31	42	48	M6	1600	110	130	0.58
D-42	42	75	30	36	50	58	M8	2500	110	130	1
D-45	45	75	30	36	50	58	M8	2500	150	130	0.97
D-48	48	80	30	36	50	58	M8	3700	150	170	1.08
D-50	50	80	30	36	50	58	M8	3700	150	170	1.05
D-55	55	85	30	36	50	58	M8	4100	150	160	1.14
D-60	60	90	30	36	50	58	M8	4500	160	160	1.18
D-65	65	95	30	36	50	58	M8	4500	160	150	1.26
D-70	70	110	39	46	60	70	M10	8400	240	150	2.25
D-75	75	115	39	46	60	70	M10	8400	240	140	2.43
D-80	80	120	39	46	60	70	M10	9600	250	140	2.6
D-85	85	125	39	46	60	70	M10	11000	250	150	2.7
D-90	90	130	39	46	60	70	M10	13000	300	150	2.8
D-95	95	135	39	46	60	70	M10	13000	300	150	3
D-100	100	145	46	52	68	80	M12	17500	350	150	4.1
D-110	110	155	46	52	68	80	M12	20000	300	150	4.4
D-120	120	165	46	52	68	80	M12	21300	330	150	4.8
D-130	130	180	46	52	68	80	M12	28000	350	150	5.7
D-140	140	190	51	58.5	76	90	M14	30400	350	150	6.2
D-150	150	200	51	58.5	76	90	M14	39000	400	160	7.1
D-160	160	210	51	58.5	76	90	M14	41700	400	170	8
D-170	170	225	51	58.5	76	90	M14	52000	460	160	11
D-180	180	235	51	58.5	76	90	M14	55000	460	170	12