

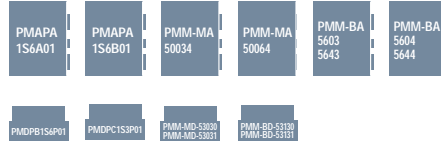

## 5-phase stepping motor

**86mm cir.** 103H858□-□□□□  
0.72°/step

● Applicable drivers



## Specifications

Model number		Holding torque at 5-phase energization	Rated current	Wiring resistance	Wiring inductance	Rotor inertia	Weight
Single-axis	Dual-axis	N.m or more	A/phase	Ω/phase	mH/phase	x 10 <sup>-4</sup> kg·m <sup>2</sup>	kg
103H8581-7041	-7011	2.06	0.75	5.7	25	1.45	1.5
103H8581-8041	-8011	2.06	1.5	1.5	5.6	1.45	1.5
103H8582-7041	-7011	4.02	0.75	8.6	41	2.9	2.5
103H8582-8041	-8011	4.02	1.5	2	10.6	2.9	2.5
103H8583-7041	-7011	6.17	0.75	10.5	59	4.4	3.5
103H8583-8041	-8011	6.17	1.5	2.5	15	4.4	3.5

## Dimensions (unit: mm)

103H8581-7041/8041 (Single shaft)  
103H8581-7011/8011 (Double shaft)

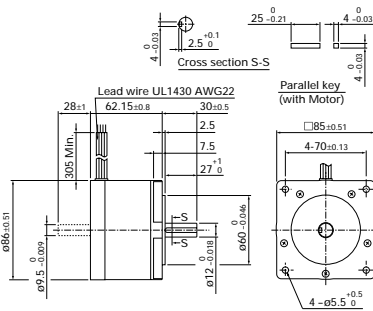

103H8582-7041/8041 (Single shaft)  
103H8582-7011/8011 (Double shaft)

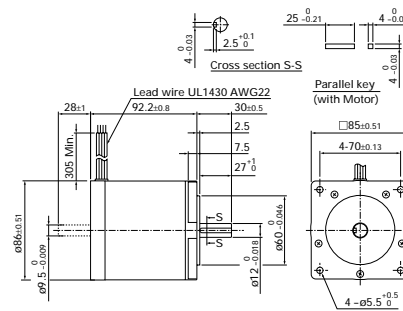

103H8583-7041/8041 (Single shaft)  
103H8583-7011/8011 (Double shaft)

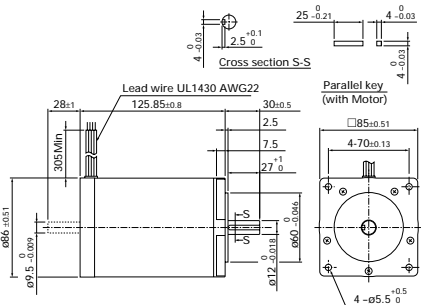

# Pulse rate-torque characteristics

## ●103H8581-7041

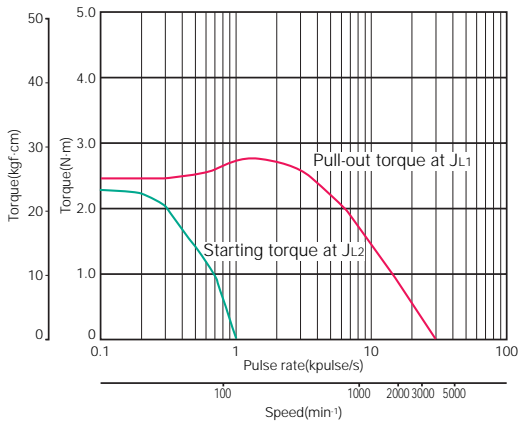

Sanyo constant current circuit  
 Source voltage : 100V AC · Winding current : 0.75A/phase  
 5-phase excitation (Full step)  
 $J_{L1}=7.4 \times 10^{-4} \text{kg} \cdot \text{m}^2$  (With rubber coupling)  
 $J_{L2}=1.45 \times 10^{-4} \text{kg} \cdot \text{m}^2$  (Pulley balancer system)

## ●103H8581-8041

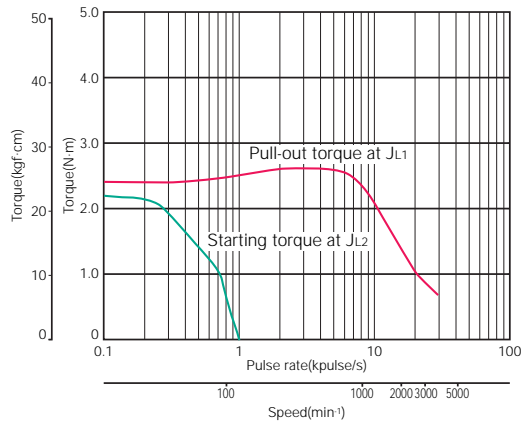

Sanyo constant current circuit  
 Source voltage : 100V AC · Winding current : 1.5A/phase  
 5-phase excitation (Full step)  
 $J_{L1}=7.4 \times 10^{-4} \text{kg} \cdot \text{m}^2$  (With rubber coupling)  
 $J_{L2}=1.45 \times 10^{-4} \text{kg} \cdot \text{m}^2$  (Pulley balancer system)

## ●103H8582-7041

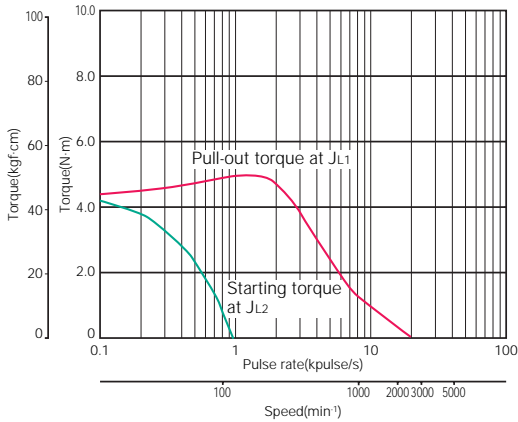

Sanyo constant current circuit  
 Source voltage : 100V AC · Winding current : 0.75A/phase  
 5-phase excitation (Full step)  
 $J_{L1}=15.3 \times 10^{-4} \text{kg} \cdot \text{m}^2$  (With rubber coupling)  
 $J_{L2}=2.9 \times 10^{-4} \text{kg} \cdot \text{m}^2$  (Pulley balancer system)

## ●103H8582-8041

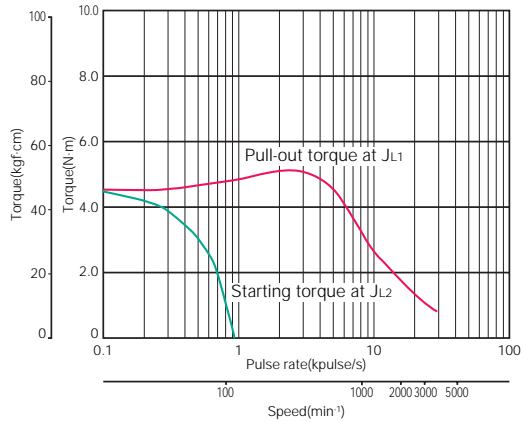

Sanyo constant current circuit  
 Source voltage : 100V AC · Winding current : 1.5A/phase  
 5-phase excitation (Full step)  
 $J_{L1}=15.3 \times 10^{-4} \text{kg} \cdot \text{m}^2$  (With rubber coupling)  
 $J_{L2}=2.9 \times 10^{-4} \text{kg} \cdot \text{m}^2$  (Pulley balancer system)

## ●103H8583-7041

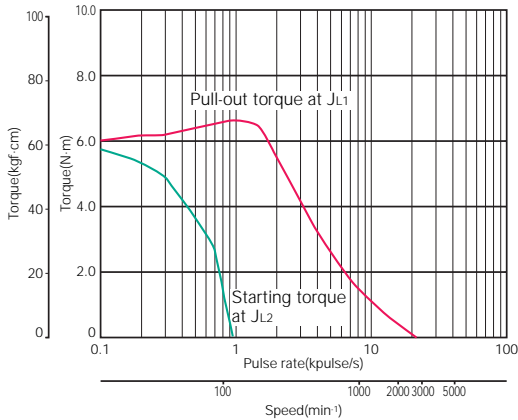

Sanyo constant current circuit  
 Source voltage : 100V AC · Winding current : 0.75A/phase  
 5-phase excitation (Full step)  
 $J_{L1}=43 \times 10^{-4} \text{kg} \cdot \text{m}^2$  (With rubber coupling)  
 $J_{L2}=4.4 \times 10^{-4} \text{kg} \cdot \text{m}^2$  (Pulley balancer system)

## ●103H8583-8041

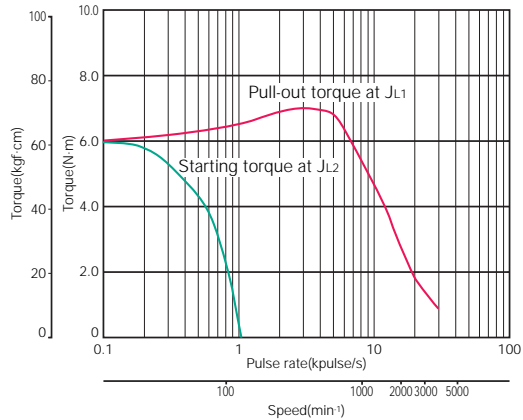

Sanyo constant current circuit  
 Source voltage : 100V AC · Winding current : 1.5A/phase  
 5-phase excitation (Full step)  
 $J_{L1}=43 \times 10^{-4} \text{kg} \cdot \text{m}^2$  (With rubber coupling)  
 $J_{L2}=4.4 \times 10^{-4} \text{kg} \cdot \text{m}^2$  (Pulley balancer system)

- 39mm (0.36")
- 60mm (0.45")
- 28mm (0.72")
- 42mm (0.72")
- 50mm (0.72")
- 60mm (0.72")
- 86mm (0.72")
- 106mm (0.72")
- CE marked
- Specifications of 5-phase stepping motor
- In-vacuum stepping motor